



Professional Grade 800 Cantilever Single Twisting Machine with 2 Year Warranty!

The quality of our **800 Cantilever Single Twisting Machine** is second to none.

Merits:

1.our **800 Cantilever Single Twisting Machine** can help you save 40% cost at the beginning, Products are widely used in **IT communications, aerospace, military, medical, locomotives, automobiles, robots, ships, 5G cloud databases and other fields.**

2.**800 Cantilever Single Twisting Machine** applied to the twisting of above 7pcs of bare copper wires,tinned wires,silver jacketed wires and enamelled wires and twisting for core wires

3.**800 Cantilever Single Twisting Machine** can do conductor stranding and cores laying up for single core ϕ 1.5mm- ϕ 4.0mm up to 12.0mm .

4.**800 Cantilever Single Twisting Machine** use cantilever structure, small rotatory inertia,high and stable rotation, thus get the stable quality products

5.**800 Cantilever Single Twisting Machine** take-up box reciprocate,lead to the bunching wire is arranged precisely in the take-up bobbin.

6.**800 Cantilever Single Twisting Machine** use computer control the pitch,no capstan,no dynamic plate, assure the uniformity tension of cable, shorten the path length。

7.Our **800 Cantilever Single Twisting Machine** increasing the diameter of veer wheel to decrease the wire bend degree, assure the quality of finished wire

8.Compared with the traditional cable-laying machine,**800 Cantilever Single Twisting Machine** can avoid the rod cracked and other unsafe factors when machine is rotating in high speed.

9.Type:

800 Cantilever Single Twisting Machine for cores twisting and conductor compress stranding (refer to page 5-8)

800 Cantilever Single Twisting Machine for cores twisting and conductor compress stranding (refer to page 9-12)



10. Can fit 380V to 440V, 50HZ to 60HZ, color can be customize
3 phase 4 wires, R, S, T, PEN
3 phase 5 wires, R, S, T, PE, N



11. Some Option:

Set-up:

Veinview HMI + Siemens PLC & Yaskawa Inverter + Siemens Motor
Siemens HMI & PLC & Inverter + Siemens Motor

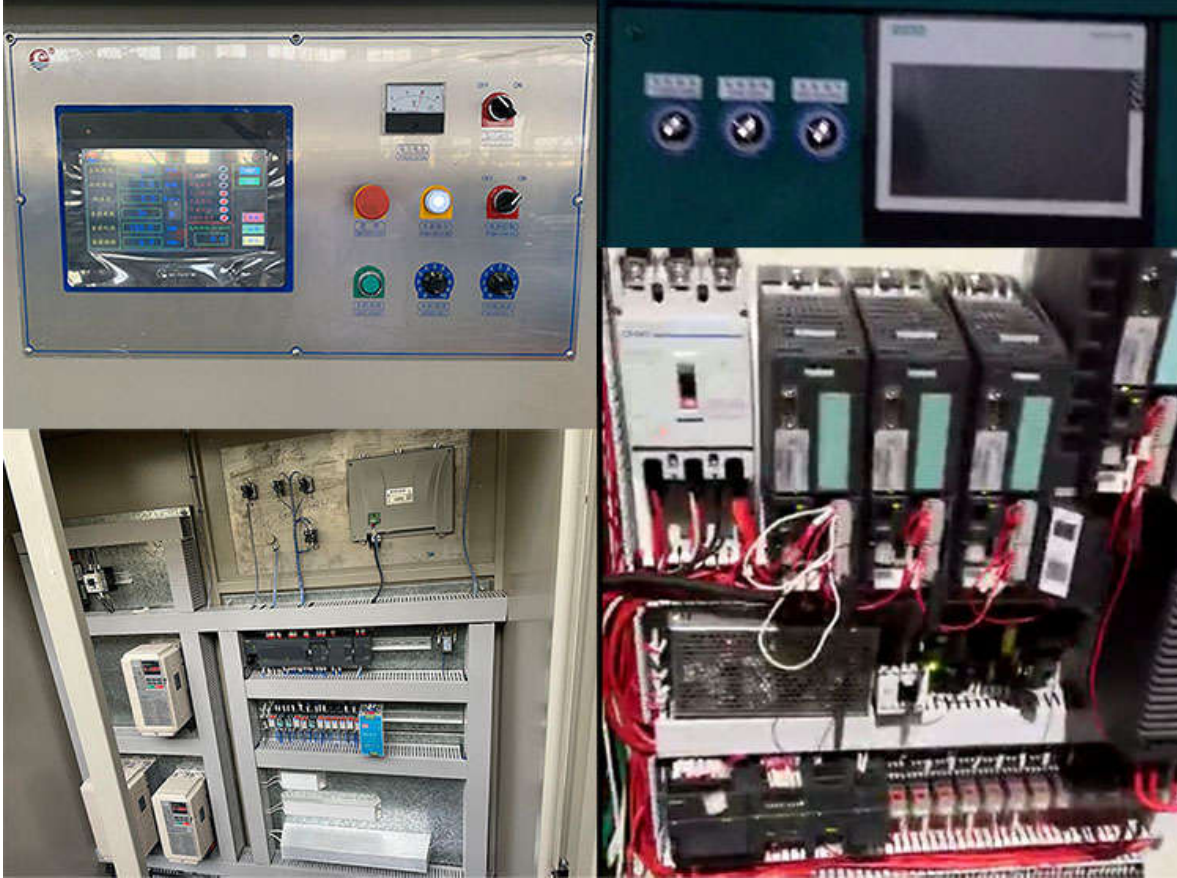

IOT remote system and temperature sensor





CABLEMACH.COM

Cable Machinery | Solutions !

www.cablemach.com
sales@cablemach.com
Lance : +86 15216844360

Trade terms: T/T, L/C.

Package:

- 1.Simple water-prof package
- 2.Pallet package
- 3.Pallet with Vacuum package
- 4.Wooden box package





800 Cantilever Single Twisting Machine Specification

Application: apply for insulated cores cable laying up.

Direction: from left to Right ,(Face to the operate panel, pay-off on the left, take-up on the right)

Coating: Main Color RAL5015 Sky blue, Safety Color Orange;Power cabinet Cabinet White(Or customize)

Power Supply: 380V 50HZ;

Load Capacity: 32KVA

Compressed air:0.4-0.8Mpa

➤ **Main accessories brand:**

- 1.Motor: Siemens
- 2.Inverter: YASKWA
- 3.Pitch Controller: Computer pitch
- 4.PLC:Siemens

➤ **Composition Specifications:**

800 Cantilever Single Twister host

- 1.Spool: OD Max800mm * OW Max 600mm
- 2.Inlet core range: ϕ 1.5-5.0mm (0.5mm² - 6.0mm² flexible cable)
- 3.Finished OD: Max 10mm
- 4.Pitch: 40-200mm, adjust by computer (or Customize)
- 5.Speed: Max 600RPM
- 6.Power: 20HP
- 7.Brake: Pneumatic pressurized brake device;
- 8.Safety device:Spool lifting and safety reset detection。
- 9.Dimension: L 5100 * W 1500* H 1550
- 10.Net Weight: 2100KG

800 Central Taping:

- 1.Adapter models:800 single twister
- 2.The tape tension is given by magnetic powder to ensure the stability of the tension and the consistency of the elasticity.
- 3.The synchronous speed is given by the take-up linkage to ensure the uniformity and pitch of the belt, and it is driven by the synchronous belt to ensure smooth transmission.
- 4.Speed: Max 2500RPM
- 5.Power:2.2KW-2P
- 6.Material: Cotton paper, Mylar tape, aluminum foil.
- 7.Tape Size: OD300mm, width 15-30mm
- 8.Auto-stop when tape cut-off

Constant tension side-along taping

- 1.Powder Clutch side-along taping OD:400mm



2. Material Size: OD 250*ID 50*Width 15-35mm
3. Material: Cotton paper, Mylar tape, aluminum foil.
4. Constant tension controller (can display the current tension), automatically adjust the tension of the tape with the size of the aluminum foil tray, with a tension sensor, online feedback tension to the controller, and control the output tension of the magnetic powder..
5. Auto-stop when tape cut-off or finished

630 insulated wire pay-off (Filling bracket 4)

1. Application: apply for insulated core only
1. Wire range: ϕ 1.5 - ϕ 5.0mm
3. Spool size: 400/500/630mm
4. Tension control: Spring tension dancer
5. Brake: belt brake when wire cut-off
6. Capacity: Max 150KG
7. Spool loading: Manual
8. Heads: 12Head* 1 set

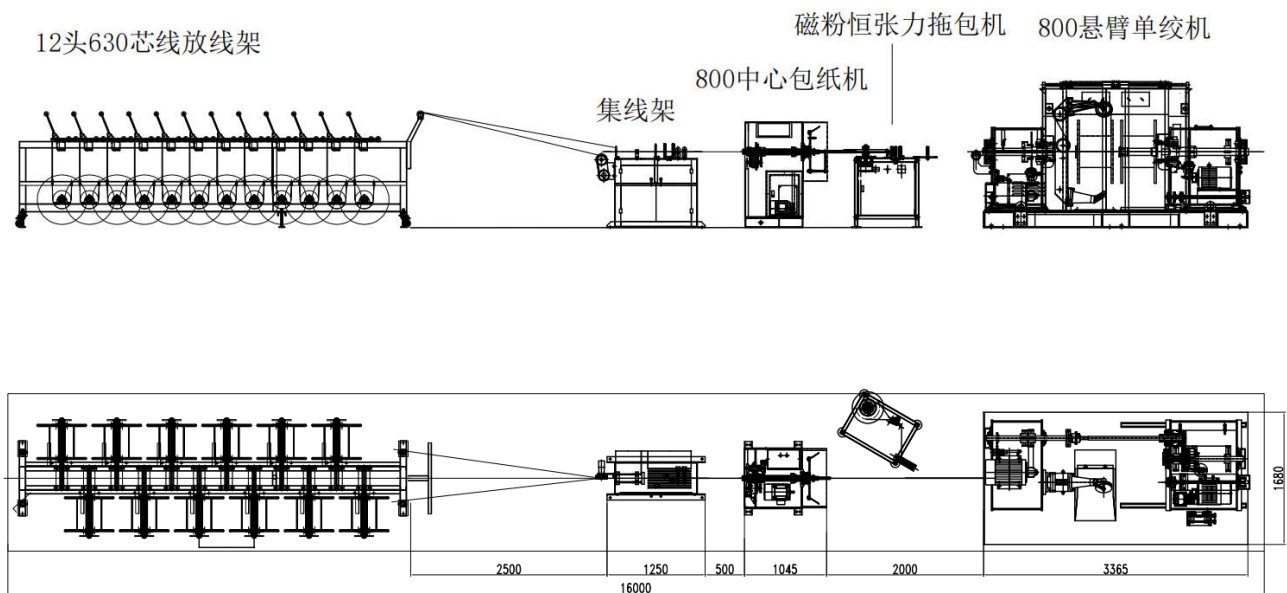



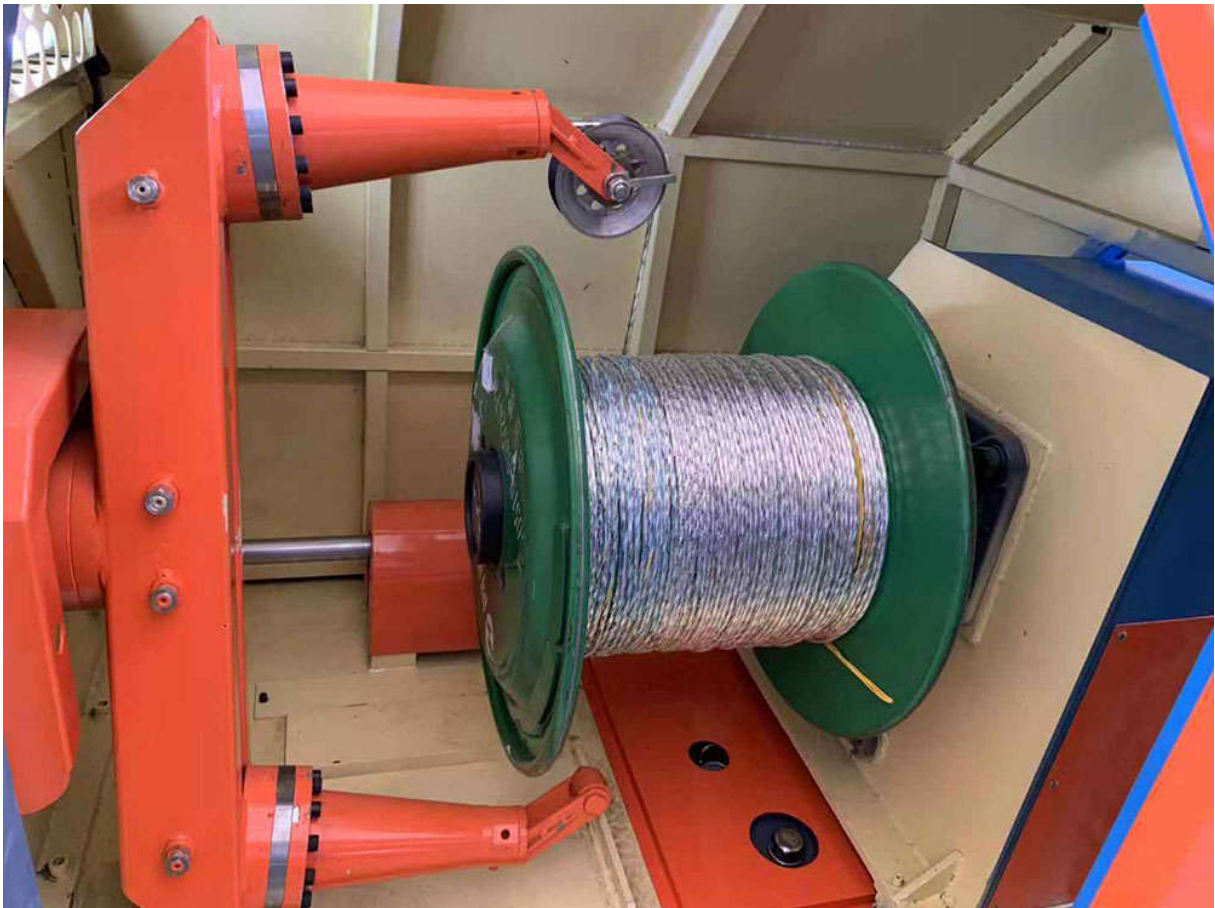



800 Cantilever Single Twisting Machine Specification

Application: apply for insulated cores cable laying up.

Direction: from left to Right ,(Face to the operate panel, pay-off on the left, take-up on the right)

Coating: Main Color RAL5015 Sky blue, Safety Color Orange;Power cabinet Cabinet White(Or customize)

Power Supply: 380V 50HZ;

Load Capacity: 32KVA

Compressed air:0.4-0.8Mpa

➤ **Main accessories brand:**

- 1.Motor: Siemens
- 2.Inverter: YASKWA
- 3.Pitch Controller: Computer pitch
- 4.PLC:Siemens

➤ **Composition Specifications:**

800 Cantilever Single Twister host

- 1.Spool: OD Max800mm * OW Max 600mm
- 2.Inlet core range: ϕ 1.5-4.0mm (0.3mm² - 4.0mm² flexible cable)
- 3.Finished OD: Max 12mm
- 4.Pitch: 45-260mm, adjust by computer (or Customize)
- 5.Speed: Max 600RPM
- 6.Power: Host 15KW-4P, take-up 5.5KW-6P, traverse 0.75KW-4P
- 7.Invertor: Yaskawa (ost 15KW-4P, take-up 5.5KW-6P, traverse 0.75KW-4P)
- 8.Brake: Pneumatic pressurized brake device;
- 9.Safety device:Spool lifting and safety reset detection。
- 10.Dimension: L 5100 * W 1500* H 1550
- 11.Net Weight: 2100KG

800 Central Taping:

- 1.Adapter models:800 single twister
- 2.The tape tension is given by magnetic powder to ensure the stability of the tension and the consistency of the elasticity.
- 3.The synchronous speed is given by the take-up linkage to ensure the uniformity and pitch of the belt, and it is driven by the synchronous belt to ensure smooth transmission.
- 4.Speed: Max 2500RPM
- 5.Power:1.5KW-2P
- 6.Material: Cotton paper, Mylar tape, aluminum foil.
- 7.Tape Size: OD300mm, width 15-30mm

Constant tension side-along taping

- 1.Powder Clutch side-along taping OD:400mm



- 2. Material Size: OD 250*ID 50*Width 15-35mm
- 3. Material: Cotton paper, Mylar tape, aluminum foil.
- 4. Constant tension controller (can display the current tension), automatically adjust the tension of the tape with the size of the aluminum foil tray, with a tension sensor, online feedback tension to the controller, and control the output tension of the magnetic powder..
- 5. Auto-stop when tape cut-off or finished

630 insulated wire pay-off (shaft type)

- 1. Spool size: 500/630mm spool (or customize)
- 2. Wire range: ϕ 1.5 - ϕ 4.0mm insulated core
- 3. 1.2kgf magnetic powder tension control (adjustable according to different specifications, digital display control) + spring-type dancer to control the pay-off tension.
- 4. Magnetic powder clutch
- 5. Spool loading: Manual hydraulic fork truck (client-owned)
- 6. Spool fix type: shaft type
- 7. Heads: 8Head* 1 set

➤ **Equipment configuration instructions**

Description	Model	Remark
1.Host Motor	15KW-4P-B3	Siemens
2.Take-up Motor	5.5KW-6P	TECO
3.Traverse Motor	CH28-750-10S-G2	DCG
4.Central Taping Motor	1.5KW-2P	TECO
5.Invertor		Yaskawa
6.PLC		Siemens
7.Touch Screen	RGB 10 inch	TAIWAN
8.Pneumatic brake		TAIWAN
9.Linear slide	BRH-35A	HIWIN
10.Bearing	1SET	NSK、NTN、GLH
11.Timing Belt	1SET	Imported
12.Electric hydraulic pump	10T	TAIWAN
13. Body	1SET	Self-Processing
14. Spindle	2PCS	Self-Processing
15. Bearing Housing	1SET	Self-Processing
16. transmission shaft	1PCS	Outsourcing
17. Wiring wheel	3PCS	Self-Processing
18.Pay-off powder clutch 1.2kgf	1SET	TAIWAN
19.Contactror, circuit breaker, switch		Schneider
20.Encoder		NEMICON
21.Relay		Omron

